

AIR HYDRAULIC CART, AIR-800-D

****Any additions, deletions or omissions must be corrected on this drawing, as this drawing will be considered all inclusive.****

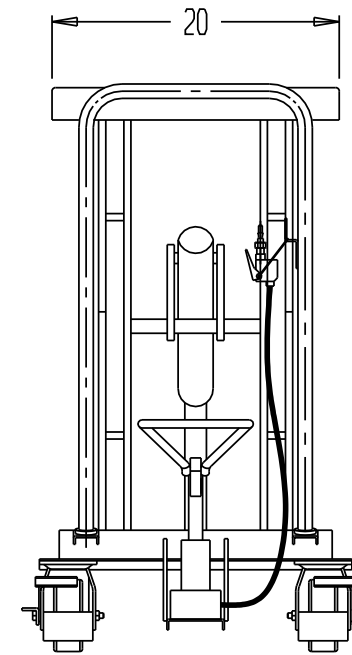
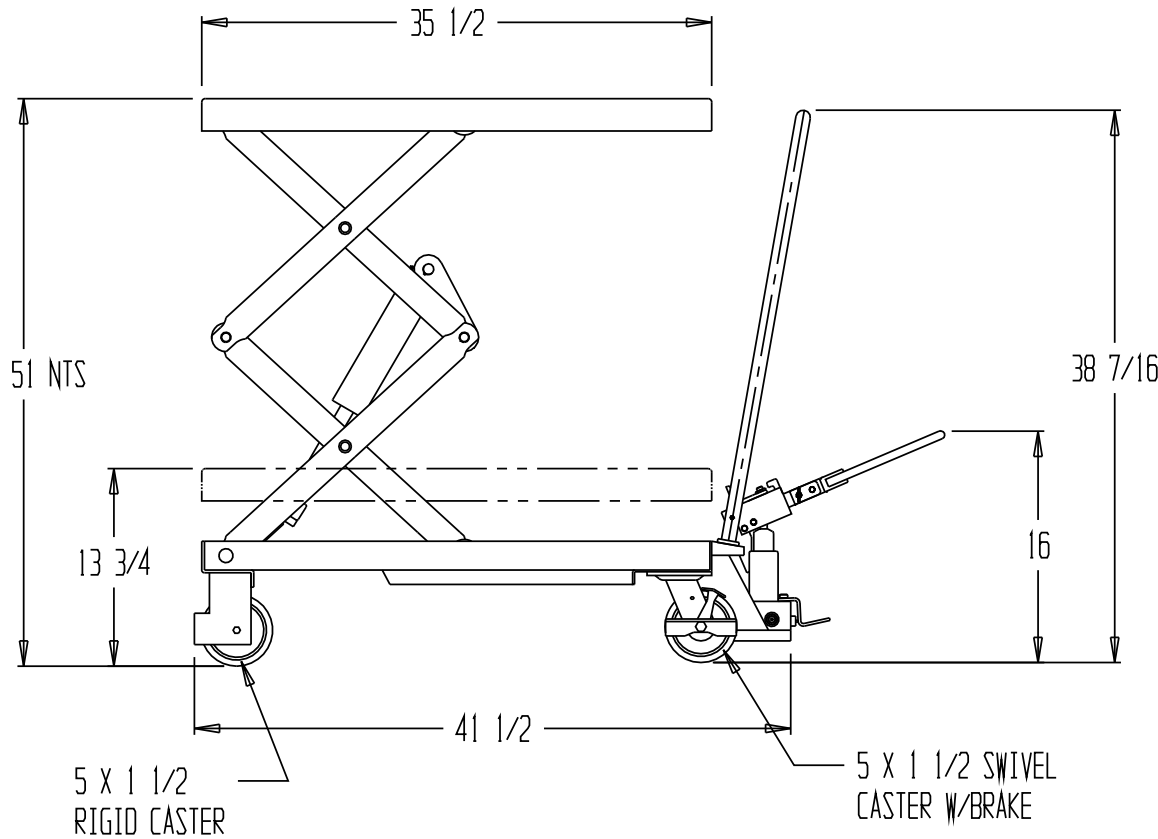

LEAD TIME WILL START UPON RECEIPT OF SIGNED APPROVAL DRAWING

STANDARD FEATURES

- MODEL NUMBER: AIR-800-D
- CAPACITY: 800 LBS.
- PLATFORM WIDTH: 20"
- PLATFORM LENGTH: 35 1/2"
- PLATFORM RAISED HEIGHT: 51"
- PLATFORM LOWERED HEIGHT: 13 3/4"
- OPERATION: TWO SPEED FOOT PUMP
OR HAND HELD RECIPROCATING AIR/OIL

SPECIAL FEATURES

NONE

****SPECIAL UNITS ARE NON-RETURNABLE
*AVAILABLE AT ADDITIONAL COSTS**

***** ALL GRAPHICS PROVIDED ARE FOR REFERENCE ONLY. IF CERTAIN DIMENSIONS ARE CRITICAL PLEASE VERIFY THOSE DIMENSIONS WITH YOUR SALESPERSON. *****

APPROVAL

I, the undersigned, hereby approve this print
 As drawn As marked

This includes my approval of design & dimensions.

Signed: _____

Date: _____

DISTRIBUTOR'S NAME:		P.O.#: -
VESTIL MANUFACTURING		W.O.#: -
DRAWN BY: SR	DATE: 1-22-09	SALES: -
REFERENCE:		DRWG./FILE NAME:
-	SCALE: 1:14	AIR-800-D