

CARGO HOOP - CH-7

APPROX WEIGHT: 5.43 lbs.
 DOES NOT INCLUDE WEIGHT OF POWER OR PACKAGING!!!

*** ANY ADDITIONS, DELETIONS, OR OMISSIONS MUST BE CORRECTED ON THIS DRAWING AS THIS DRAWING WILL BE CONSIDERED ALL INCLUSIVE ***

ALL GRAPHICS PROVIDED ARE FOR REFERENCE ONLY. IF CERTAIN DIMENSIONS ARE CRITICAL PLEASE VERIFY THOSE DIMENSIONS WITH YOUR SALESPERSON

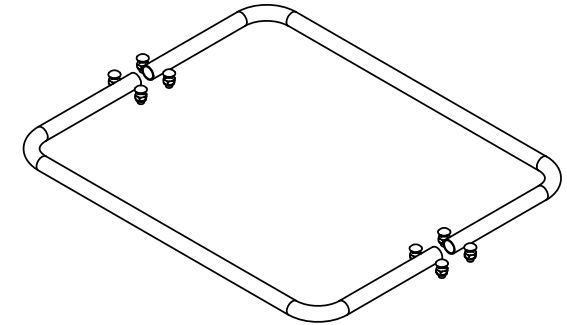
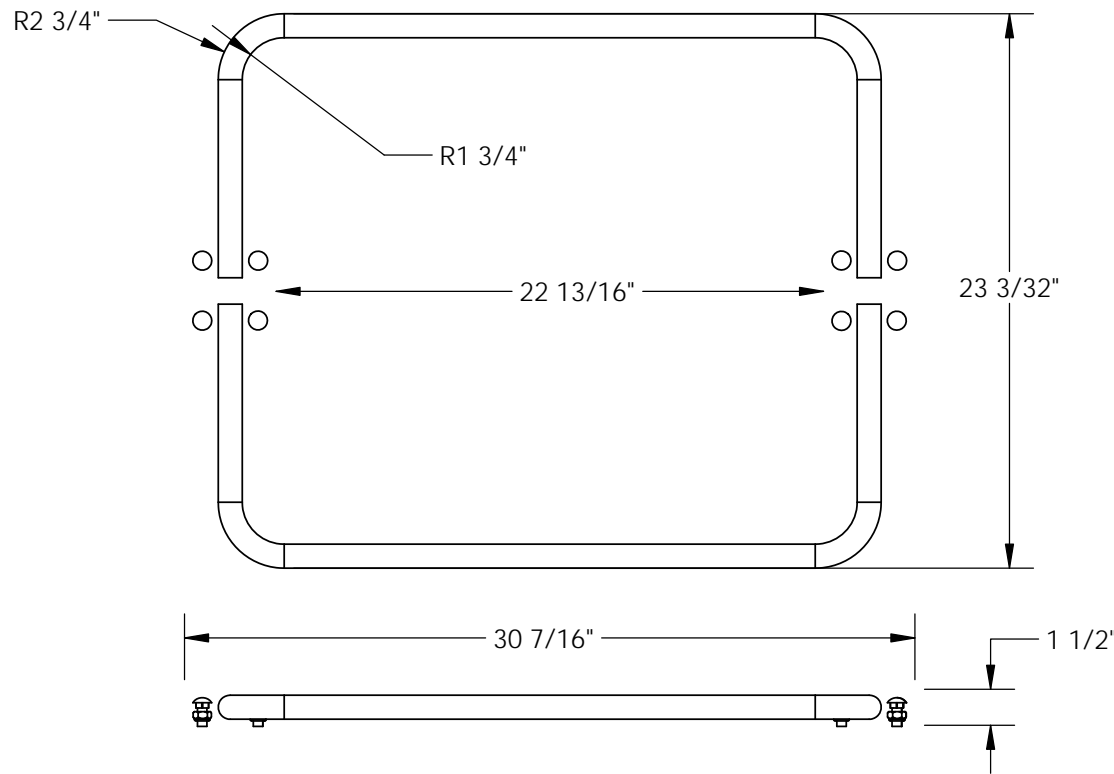

STANDARD FEATURES

- MODEL NUMBER IS: CH-7
- OVERALL WIDTH IS: 30 7/16"
- USABLE WIDTH IS: 30 7/16"
- OVERALL LENGTH IS: 1 1/2"
- USABLE LENGTH IS: 1 1/2"
- OVERALL HEIGHT IS: 23 3/32"
- UNIT SOLD AS A PAIR

SPECIAL FEATURES

NONE

DIMENSION TOLERANCE $\pm 1/4"$

APPROVAL	I, THE UNDERSIGNED, AGREE THAT THE PRODUCT AS REPRESENTED SATISFIES DESIGN AND DIMENSION REQUIREMENTS. I ALSO ACKNOWLEDGE MY DUTY TO CONFIRM PRODUCT AND INSTALLATION COMPLIANCE WITH ALL APPLICABLE FEDERAL, STATE AND LOCAL REGULATIONS AND STANDARDS.	
	ALL SPECIAL UNITS ARE NON-RETURNABLE <input type="checkbox"/> As drawn <input type="checkbox"/> As marked	
Signed: _____		Date: _____
LEAD TIME WILL START UPON RECEIPT OF SIGNED APPROVAL DRAWING		

DISTRIBUTOR'S NAME:		P.O.#
VESTIL MANUFACTURING		X
DRAWN BY: ALH		W.O.#
DATE: 07/08/2011		X
REFERENCE: X	SCALE: 1:8	SALES: X
QUOTED LEAD TIME: X	QUOTE #	FILE NAME:
	X	44-007-325