

ELECTRIC HYDRAULIC SCISSOR LIFT TABLE - EHLT-4848-4-43

APPROX WEIGHT: 759.25 lbs.
DOES NOT INCLUDE WEIGHT OF POWER OR PACKAGING!!!

*** ANY ADDITIONS, DELETIONS, OR OMISSIONS MUST BE CORRECTED ON THIS DRAWING AS THIS DRAWING WILL BE CONSIDERED ALL INCLUSIVE ***

ALL GRAPHICS PROVIDED ARE FOR REFERENCE ONLY. IF CERTAIN DIMENSIONS ARE CRITICAL PLEASE VERIFY THOSE DIMENSIONS WITH YOUR SALESPERSON

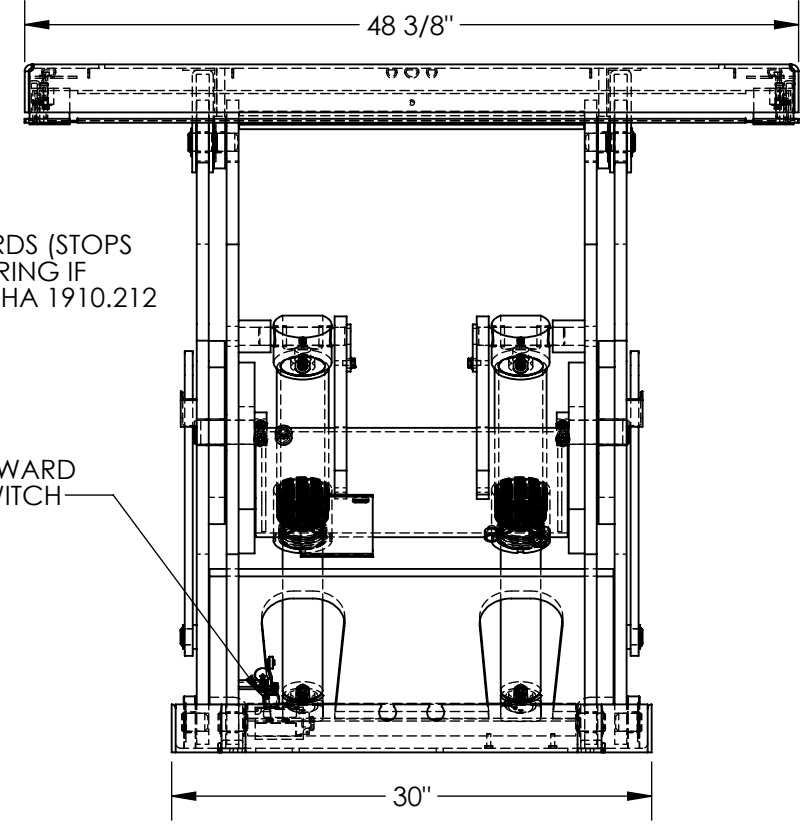
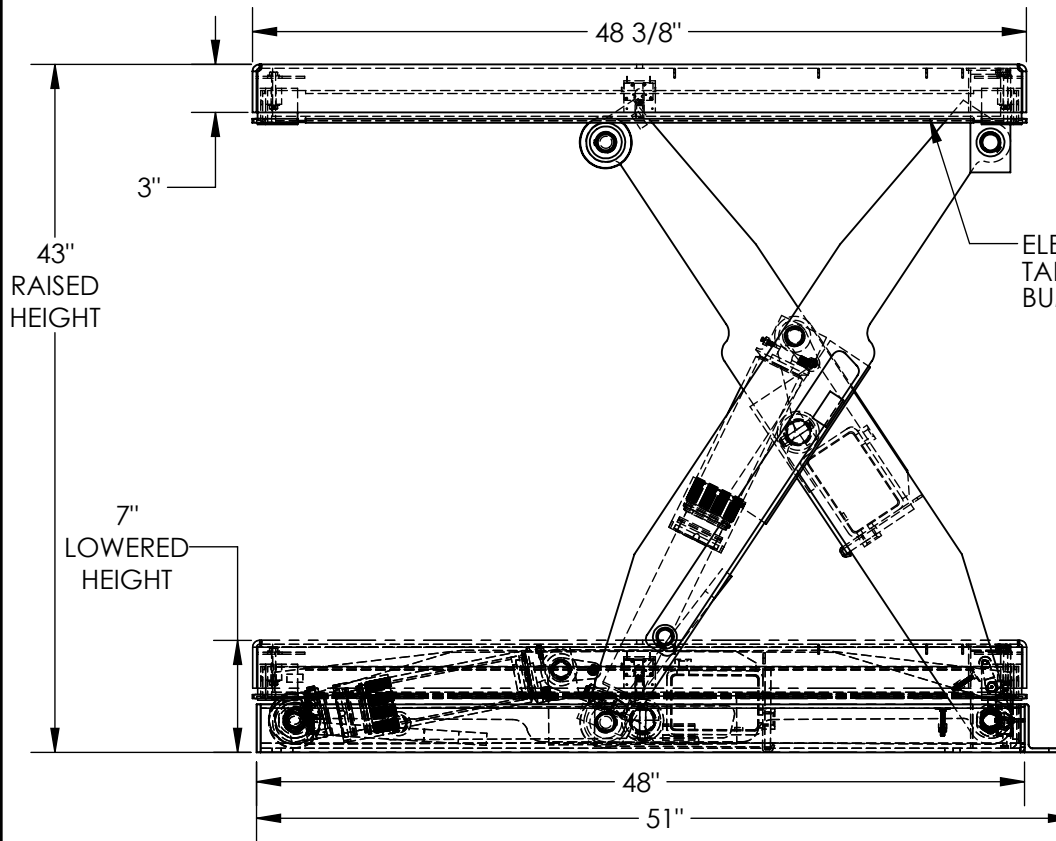

ELECTRIC TOEGUARDS (STOPS TABLE FROM LOWERING IF BUMPED) MEETS OSHA 1910.212

ADJUSTABLE UPWARD TRAVEL LIMIT SWITCH

DIMENSION TOLERANCE $\pm 1/4"$

STANDARD FEATURES

- MODEL NUMBER IS EHLT-4848-4-43
- PLATFORM WIDTH IS 48 3/8"
- PLATFORM LENGTH IS 48 3/8"
- OVERALL LENGTH IS 51"
- PLATFORM RAISED HEIGHT IS 43"
- PLATFORM LOWERED HEIGHT IS 7"
- TABLE CAPACITY (EVENLY DISTRIBUTED) LOAD IS 4,000 LBS
- CONTROLS HAND PENDANT ON 8' CORD
- SAFETY MAINTENANCE PROPS, DISPLACEMENT STYLE CYLINDERS INSTALLED ROD DOWN
- EMERGENCY SAFETY STOP HYDRAULIC FUSES IN ALL CYLINDER UNITS HAVE 2' TEST LEAD AND PIG TAIL
- DURABLE LIQUID PAINT BLUE FINISH

PLEASE CIRCLE SPECIFICATIONS:

POWER	AC	DC (12V)	AIR/OIL
MOTOR VOLTAGE	115	208	230 460
DEDICATED CIRCUIT REQUIRED 60Hz			
MOTOR PHASE	SINGLE	THREE	
CONTROL	HAND	FOOT	

APPROVAL

I, THE UNDERSIGNED, AGREE THAT THE PRODUCT AS REPRESENTED SATISFIES DESIGN AND DIMENSION REQUIREMENTS. I ALSO ACKNOWLEDGE MY DUTY TO CONFIRM PRODUCT AND INSTALLATION COMPLIANCE WITH ALL APPLICABLE FEDERAL, STATE AND LOCAL REGULATIONS AND STANDARDS.

ANY MODIFIED UNITS ARE NON-RETURNABLE

[] As drawn [] As marked

Signed: _____ Date: _____

Printed Name: _____

LEAD TIME WILL START UPON RECEIPT OF SIGNED APPROVAL DRAWING

SPECIAL FEATURES

NONE

- DECK TOLERANCE $\pm 1/2"$
- TABLE HEIGHT TOLERANCE $\pm 1/2"$
- DECK FLATNESS $\pm 1/4"$

FOR INTERNAL USE ONLY
PROJECT SIGN OFF

SALES	
ENG.	
FAB.	
POWER	

DISTRIBUTOR'S NAME:		P.O.#
VESTIL MANUFACTURING		X
W.O.#		X
DRAWN BY: BCN	DATE: 08/29/2017	SALES: X
REFERENCE: X	SCALE: 1:12	FILE NAME:
QUOTED LEAD TIME: X	QUOTE # X	24-007-111-003