

4325

2500 ml Packo

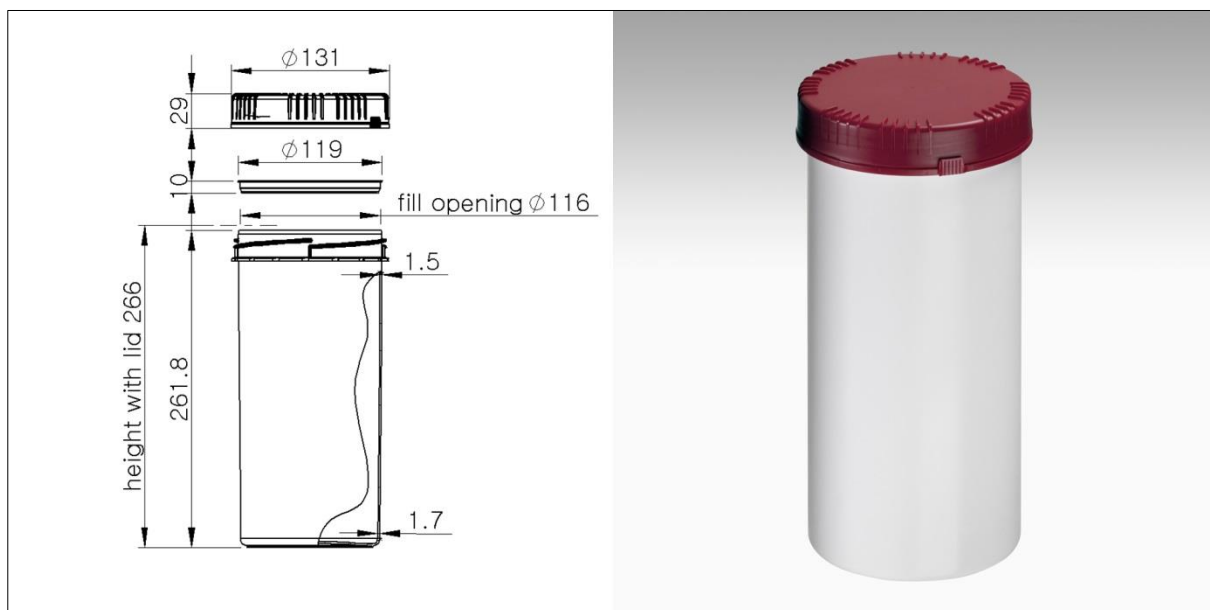

*For tolerances see next page

Product part	Product code	Description
Container	4325-60-004	2500ml Packo
Lid	4355-70-402	Screw lid
Inner seal	4360-00-000	Inner seal

Capacity	ml	floz
Brimful	2630	88.9
When closed	2500	84.5

Raw material	
Container	HDPE
Lid	HDPE
Inner seal	MDPE

Weight	Grams	Ounces
Container	175	6.17
1C Lid	39.6	1.4
Inner seal	13.6	0.48
Total	228.2	8.05

Colours	Colour code	PMS references
Container	White 004	n/a
Lid	Red 402	Red 199 C
	Yellow 205	Yellow 108C
	Grey 135	Cool Gray 7 C
	Red 480	Red 7645 C
	Green 505	Green 378 C
	Blue 605	Blue 300 C

Hazmat information	
Hazmat type	Solids
Packaging group	I – II – III
UN marking	1H2/X3.3/S/--/B/CURTEC-080062
Maximum gross mass (kg)	X=3.3 Y=4.9 Z=7.9

Product identification	
1. Manufacturer ID	
2. Country of Origin	
3. Product no.	
4. Food grade	
5. Material type	
6. Date clock	
7. UN mark	

Other information
<p>Packo consists of a container with a transparent insert and a lid with tear-off tamper evident seal</p> <p>Open and close with just a quarter-turn</p> <p>Other colours and versions are available on request</p> <p>Maximum filling temperature is 70°C/ 158°F</p> <p>Contents must have cooled to 30°C/ 86°F before containers can be closed and stacked</p> <p>DoC available on request</p> <p>UN certificate available on request</p> <p>MVTR declaration available on request</p> <p>User manual available on request</p>

Dimensional tolerance (mm) according to DIN16742-TG7																
Over	1	>3	>6	>10	>18	>30	>50	>80	>120	>180	>250	>315	>400	>500	>630	>800
up to	3	6	10	18	30	50	80	120	180	250	315	400	500	630	800	1000
NW (±)	0.20	0.29	0.35	0.42	0.50	0.60	0.90	1.25	1.45	1.60	1.80	2.60	3.50	4.00	4.50	5.00

Weight tolerance
All products have a weight tolerance of ±4% of the initial weight mentioned on this data sheet

© 2015 Property of CurTec International B.V. All rights explicitly reserved, it is not allowed to copy or communicate to other parties without written consent of CurTec.