

# HEAVY DUTY ECONOMY CYLINDER CART WITH FIREPROOF INSERT - CYL-EH-FP-FF

\*\*\*ANY ADDITIONS, DELETIONS, OR OMISSIONS MUST BE CORRECTED ON THIS DRAWING AS THIS DRAWING WILL BE CONSIDERED ALL INCLUSIVE\*\*\*

APPROX WEIGHT: 191.94 lbs.  
DOES NOT INCLUDE WEIGHT OF POWER OR PACKAGING!!!

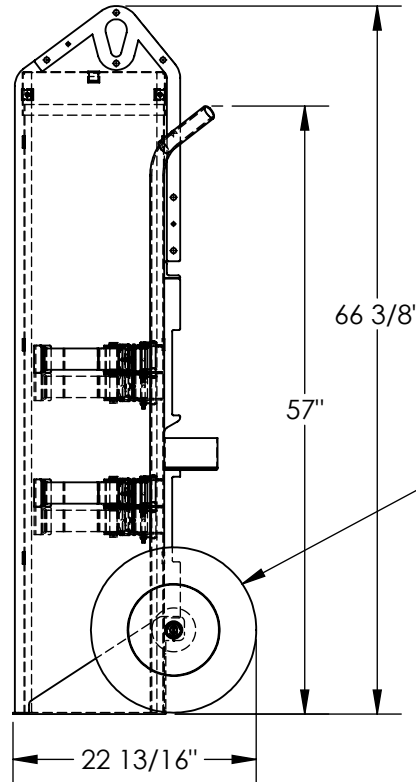
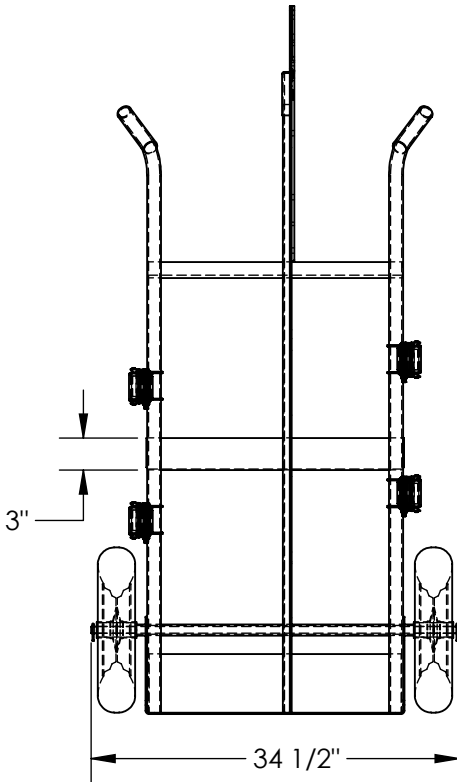
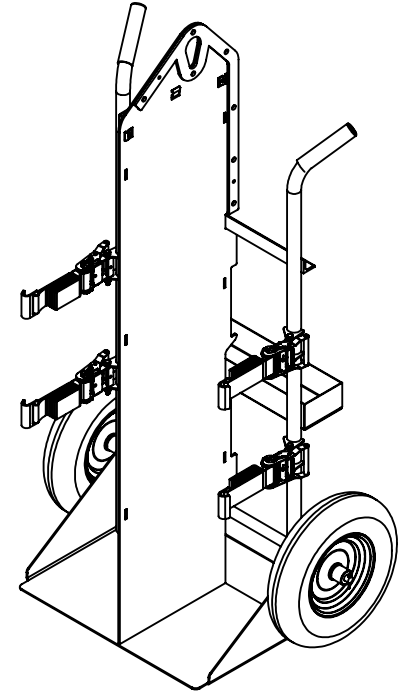
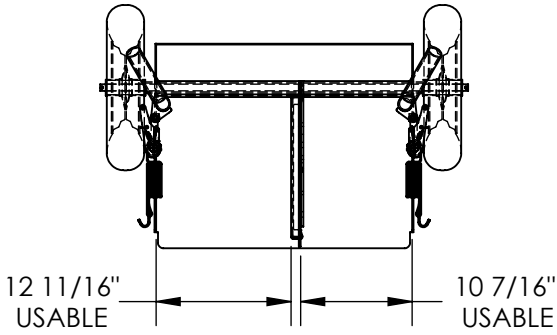

FOR INTERNAL USE ONLY PROJECT SIGN OFF	
SALES	
ENG.	
FAB.	
POWER	

ALL GRAPHICS PROVIDED ARE FOR REFERENCE ONLY. IF CERTAIN DIMENSIONS ARE CRITICAL PLEASE VERIFY THOSE DIMENSIONS WITH YOUR SALESPERSON

DIMENSION TOLERANCE +-1/4"

## STANDARD FEATURES

- MODEL NUMBER IS CYL-EH-FP-FF
- CAPACITY IS: 500 LBS
- OVERALL WIDTH IS 34 1/2"
- LEFT SIDE USABLE WIDTH IS 12 11/16"
- RIGHT SIDE USABLE WIDTH IS 10 7/16"
- OVERALL DEPTH IS 22 13/16"
- OVERALL HEIGHT IS 66 3/8"
- STRAPS TO SECURE TANKS
- DIVIDER WITH FIREPROOF MARINITE INSERT
- Ø16" FOAM FILLED WHEELS
- TOUGH BAKED IN POWDERCOATED YELLOW FINISH

## SPECIAL FEATURES

NONE

<b>A P P R O V A L</b>	I, THE UNDERSIGNED, AGREE THAT THE PRODUCT AS REPRESENTED SATISFIES DESIGN AND DIMENSION REQUIREMENTS. I ALSO ACKNOWLEDGE MY DUTY TO CONFIRM PRODUCT AND INSTALLATION COMPLIANCE WITH ALL APPLICABLE FEDERAL, STATE AND LOCAL REGULATIONS AND STANDARDS.	
	<b>ANY MODIFIED UNITS ARE NON-RETURNABLE</b>	
	[ ] As drawn      [ ] As marked	
	Signed: _____ Date: _____	
Printed Name: _____		LEAD TIME WILL START UPON RECEIPT OF SIGNED APPROVAL DRAWING

DISTRIBUTOR'S NAME:		P.O.#
<b>VESTIL MANUFACTURING</b>		X
DRAWN BY: TJM		W.O.#
DATE: 03/05/10		X
REFERENCE: X	SCALE: 1:18	SALES: X
QUOTED LEAD TIME: X	QUOTE #	FILE NAME:
	X	16-007-243