

SOLID DECK HARDWOOD DOLLIES - HDOS-1624-12

APPROX WEIGHT: 21.22 lbs.
DOES NOT INCLUDE WEIGHT OF POWER OR PACKAGING!!!

*** ANY ADDITIONS, DELETIONS, OR OMISSIONS MUST BE CORRECTED ON THIS DRAWING AS THIS DRAWING WILL BE CONSIDERED ALL INCLUSIVE ***

ALL GRAPHICS PROVIDED ARE FOR REFERENCE ONLY. IF CERTAIN DIMENSIONS ARE CRITICAL PLEASE VERIFY THOSE DIMENSIONS WITH YOUR SALESPERSON

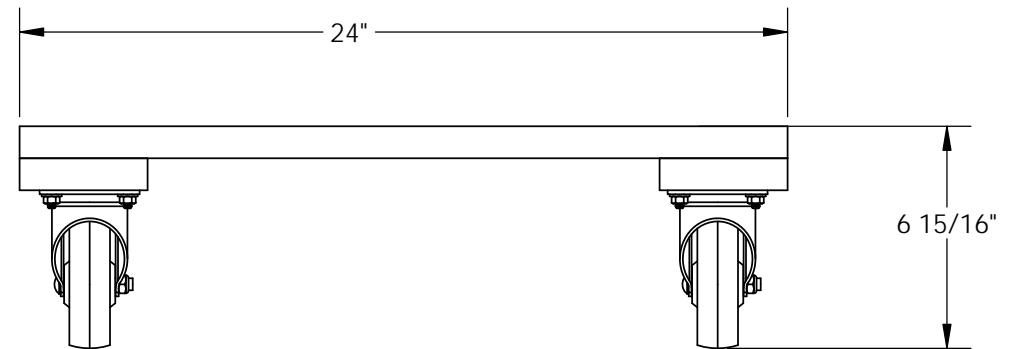
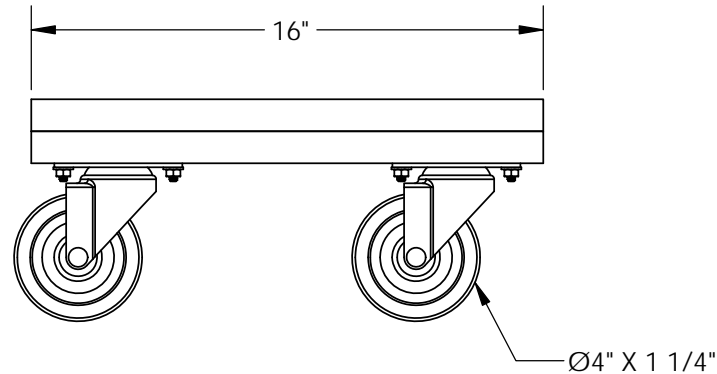
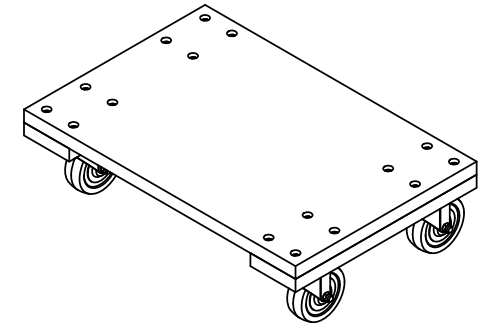

DIMENSION TOLERANCE $\pm 1/2"$

A P P R O V A L	I, THE UNDERSIGNED, AGREE THAT THE PRODUCT AS REPRESENTED SATISFIES DESIGN AND DIMENSION REQUIREMENTS. I ALSO ACKNOWLEDGE MY DUTY TO CONFIRM PRODUCT AND INSTALLATION COMPLIANCE WITH ALL APPLICABLE FEDERAL, STATE AND LOCAL REGULATIONS AND STANDARDS.	
	ANY MODIFIED UNITS ARE NON-RETURNABLE	
	[] As drawn [] As marked	
	Signed: _____	Date: _____
Printed Name: _____		
<i>LEAD TIME WILL START UPON RECEIPT OF SIGNED APPROVAL DRAWING</i>		

STANDARD FEATURES

- MODEL NUMBER IS HDOS-1624-12
- OVERALL WIDTH IS 16"
- USABLE WIDTH IS 16"
- OVERALL LENGTH IS 24"
- USABLE LENGTH IS 24"
- OVERALL HEIGHT IS 6 15/16"
- MAX CAPACITY IS 1,200 LBS.
- 4X Ø4" X 1 1/4" HARD RUBBER SWIVEL CASTERS

SPECIAL FEATURES

NONE

FOR INTERNAL USE ONLY PROJECT SIGN OFF	
SALES	
ENG.	
FAB.	
POWER	

DISTRIBUTOR'S NAME:		P.O.#
VESTIL MANUFACTURING		X
DRAWN BY: CA	DATE: 2/6/2013	W.O.#
REFERENCE: X	SCALE: 1:6	X
QUOTED LEAD TIME: X	QUOTE #	FILE NAME:
	X	16-007-011