

M&M INDUSTRIES, INC.

6.5 Gallon New Generation Pail



Prepared For: Standard Technical Specification 09/06/11
Revised: 12/09/13

General Specifications for cover:

Material:	High Density Polyethylene (HDPE)
Method of Mfg:	Injection Molding
Weight:	1.02 lbs
Cover Height:	2.50"
Min. Wall Thickness:	.090" (90 mil)
Bottom OD:	12.690"
Gasket:	Neoprene
Qty:	240 per pallet
Standard Color:	White, Red186, Blue300 Please inquire about custom colors

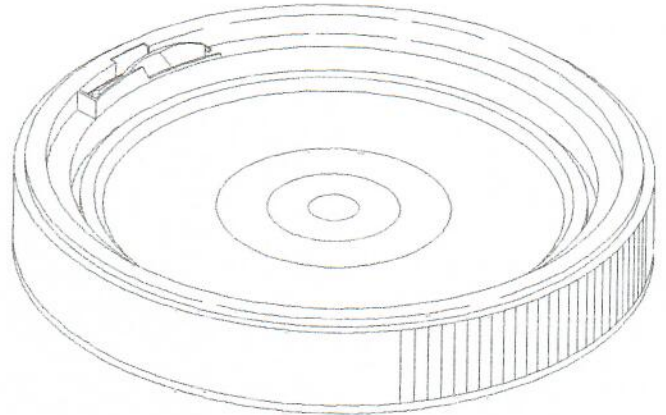

General Specifications for Pail:

Material:	High Density Polyethylene (HDPE)	
Method of Mfg:	Injection Molding	
Nominal Capacity:	6.5 Gallons	
Weight:	2.85 lbs	
Min. Wall Thickness:	.090" (90 mil)	
Exterior Height:	18.75"	
Top ID:	11.25"	
Bottom OD:	10.27 "	
Shipping Case:	2 pails and lids per case	Height
Pallet:	84 units	18.75"
Truckload:	3,360 units	
Handle:	Plastic Handle	
Printing Dimensions:	10.5" x 33"	Height
Heat Transfer Dim.:	11.438" x 31.00"	w/cover
Nesting:	Tapered walls for nesting	19.45"
Standard Color:	White	
	Please inquire about custom colors	
UN Certification:	1H2/Y30/S	

Top ID: 11.25 "

