

PALLET TRUCK WITH DIGITAL SCALE & PRINTER, PM-2748-SCL-LP-PT

NOTE:
THIS PRODUCT MAY NOT
FIT SOME STANDARD
PALLETS.

MIN LOWERED HT 3

PLEASE VERIFY YOUR
MINIMUM HT

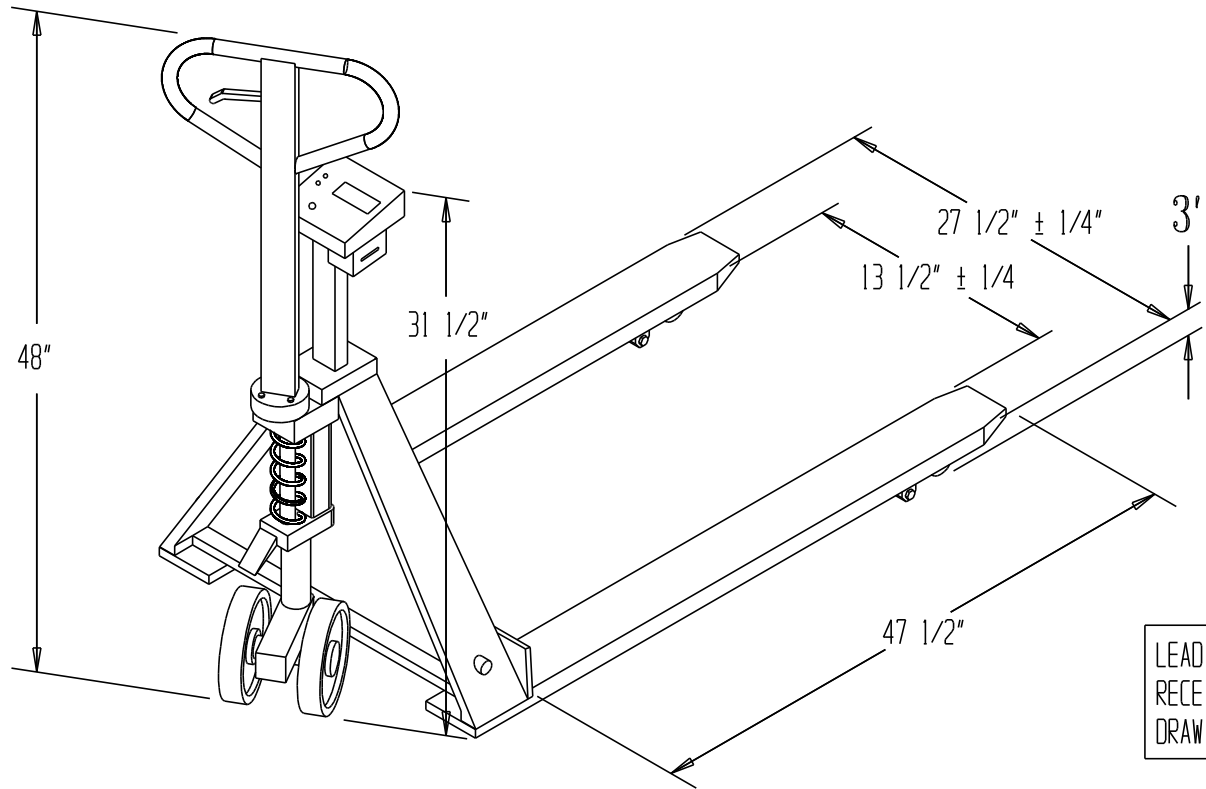

LEAD TIME WILL START UPON
RECEIPT OF SIGNED APPROVAL
DRAWING

STANDARD FEATURES

- MODEL NUMBER: PM-2748-SCL-LP-PT
- OVERALL LENGTH OF FORKS IS 47 1/2 INCHES
- OVERALL WIDTH OF FORKS IS 27 1/2 ± 1/4 INCHES
- I.D. OF FORKS IS 13 1/2 ± 1/4 INCHES
- LOWERED HEIGHT OF 3 INCHES
- RAISED HEIGHT OF 7 1/2 INCHES
- CAPACITY IS 5,000 LBS.
- POLYURETHANE WHEELS
- WEIGHT SCALE & PRINTER MOUNTED ON UNIT

SPECIAL FEATURES

NONE

**SPECIAL UNITS ARE NON-RETURNABLE
*AVAILABLE AT ADDITIONAL COSTS

APPROVAL

I, the undersigned, hereby approve this print
[] As drawn [] As marked

This includes my approval of design & dimensions.

Signed: _____

Date: _____

DISTRIBUTOR'S NAME:		P.O.#: _
VESTIL MANUFACTURING		W.O.#: _
DRAWN BY: _	DATE: _	SALES: _
REFERENCE:		DRWG./FILE NAME:
SCALE: NTS		PM-2748-SCL-LP-PT